

Simulation and Comparison of DVR and DSTATCOM Used For Voltage Sag Mitigation at Distribution Side

¹Jaykant Vishwakarma, ²Dr. Arvind Kumar Sharma

¹PG Student, High voltage and Power system, Jabalpur Engineering College, Jabalpur (M.P), India

²Associate Professor & Head of Department, Electrical Engineering Department, Jabalpur Engineering College, Jabalpur (M.P), India

Abstract: Power Quality problem in a system leads to various disturbances such as voltage fluctuations, transients and waveform distortions that results in a mis-operation or a failure of end user equipment. There are different types of custom power devices like Distribution Static Compensator (D-STATCOM) and Dynamic Voltage Restorer (DVR) which can effectively use for mitigation of different type of power quality problems. This paper describes the technique of correcting the supply voltage sag distributed system and also describes performance comparison are presented between DVR and DSTATCOM to know how both the devices successfully been applied to power system for regulating system voltage effectively. DSTATCOM and DVR both of them based on VSI principle. A DVR is a series compensation device which injects a voltage in series with system and a DSTATCOM is a shunt compensation device which injects a current into the system to correct the power quality problems. This paper presents a power system operation with PI controller with abc to dq0 convertor approach. Total Harmonics Distortion (THD) is also calculated for the system with and without compensation. Results are presented to assess the performance of devices as a potential custom power solution. Improve dynamic voltage control and thus increase system load ability. This paper presents modeling and simulation of DVR & DSTATCOM in MATLAB/Simulink.

Keywords: Power Quality, DVR, DSTATCOM, Voltage Sag, VSI, MATLAB/SIMULINK.

I. INTRODUCTION

Power distribution systems, ideally, should provide their customers with an uninterrupted flow of energy at smooth sinusoidal voltage at the contracted magnitude level and frequency [1] however, in practice, power systems, especially the distribution systems, have numerous nonlinear loads, which significantly affect the quality of power supplies. As a result of the nonlinear loads, the purity of the waveform of supplies is lost. This ends up producing many power quality problems [2]. Power quality phenomenon or power quality disturbance can be defined as the deviation of the voltage and the current from its ideal waveform. Faults at either the transmission or distribution level may cause voltage sag or swell in the entire system or a large part of it. Also, under heavy heavy load conditions, a significant voltage drop may occur in the system. Voltage sag and swell [2] can cause sensitive equipment to fail, shutdown and create a large current unbalance. These effects can incur a lot of expensive from the customer and cause equipment damage [1].

Two types of VSI-based compensators have been commonly used for mitigation of the voltage sags and swells and regulating the load voltage [5]. The first one is a shunt device, which is commonly called DSTATCOM [9]–[11], and the second one is a series device, which is commonly called DVR [5]. In [4] and [11], these compensators can address other PQ issues, such as load voltage harmonics, source current harmonics, unbalancing, etc., under steady state to obtain more

benefits out of their continuous operation. There have been a variety of control strategies proposed for load voltage control using the aforementioned two devices. For DSTATCOM, this includes reactive power compensation [9] and voltage-control mode operation of DSTATCOM [10]. For DVR, it includes open-loop and closed-loop load voltage-control methods [5].

The closed-loop voltage-control mode operation of the two devices is considered best from the point of view of precise and fast control against sudden variations in the supply voltage and the load [9]. In this paper, the performance of the DSTATCOM and the DVR used for the load bus voltage control have been analyzed and compared when power quality problems occur in the distribution system across the load bus. Both of these compensators are used under closed-loop voltage-control mode.

II. VOLTAGE SOURCE INVERTER

A voltage-source inverter is a power electronic device, which can produce a sinusoidal voltage with any required magnitude, frequency and phase angle. The VSI is used to either completely replace the voltage or to inject the 'missing voltage'. The 'missing voltage' is the difference between the nominal voltage and the actual. The converter is normally based on some kind of energy storage, which will supply the inverter with a DC voltage. A widely used method is the two level or multilevel three-phase converters which shares a dc capacitor between all phases. The purpose of this capacitor is mainly to absorb harmonic ripple and hence it has a relatively small energy storage requirement, particularly when operating in balanced conditions. The size of this capacitor has to be increased if needed to provide voltage support in unbalanced conditions. The solid-state electronics device i.e. MOSFET, GTO, IGBT etc. in the inverter is then switched to get the desired output voltage. IGBT is a three terminal controllable switch that combines the fast switching times of the MOSFET with the high voltage capabilities of the GTO used as a switching device in VSI. Normally the VSI is not only used for voltage dip mitigation, but also for other power quality issues, e.g. flicker and harmonics. The VSI connected in shunt with the ac system provides a multifunctional topology which can be used for up to three quite distinct purposes:

1. Voltage regulation and compensation of reactive power
2. Correction of power factor; and
3. Elimination of line harmonics.

III. CONTROLLER ALGORITHM

The aim of the control scheme is to maintain constant voltage magnitude at the point where a sensitive load is connected, under system disturbances. The control system only measures the r.m.s voltage at the load point i.e. no reactive power measurements are required. The VSI switching strategy is based on a PWM technique which offers simplicity and good response also PWM is used to vary the amplitude and the phase angle of the injected voltage. Since custom power is a relatively low-power application, PWM methods offer a more flexible option than the Fundamental Frequency Switching (FFS) methods favored in FACTS applications. Besides, high switching frequencies can be used to improve on the efficiency of the converter, without incurring significant switching losses.

There are several ways to control the DVR. Different parts of the controls include.

- identify the occurrence of sag / swell in the system.
- Calculate the offset voltage.
- Pulse output of the PWM inverter fire and stop it when the problem is resolved.

In normal and synchronous conditions, the voltage is a constant, d-voltage is one pu and q-voltage unit is zero pu, but in normal circumstances can be a change. The d-voltage and q-voltage with the interest that needed for best performance is compared then the d and q error is generated. Thus the d-q contents of error become abc content. Choose to provide dq0 method, give information about the size (d), phase shift (q) with start and end voltage fallen leaves. Load voltages base on the Park transformations, and according to the following equation becomes.

$$V_d = 2/3*[V_a*\sin(\omega t) + V_b*\sin(\omega t - 2\pi/3) + V_c*\sin(\omega t + 2\pi/3)]$$

$$V_q = 2/3*[V_a*\cos(\omega t) + V_b*\cos(\omega t - 2\pi/3) + V_c*\cos(\omega t + 2\pi/3)]$$

$$V_0 = 1/3*[V_a + V_b + V_c]$$

And according inverse Parks Transformation

$$V_a = [V_d*\sin(\omega t) + V_q*\cos(\omega t) + V_0]$$

$$V_b = [V_d*\sin(\omega t - 2\pi/3) + V_q*\cos(\omega t - 2\pi/3) + V_0]$$

$$V_c = [V_d*\sin(\omega t + 2\pi/3) + V_q*\cos(\omega t + 2\pi/3) + V_0]$$

where ω = rotation speed (rad/s) of the rotating frame.

Main voltages used as a Phase lock loop (PLL) to generate sine-wave single phase. The contents are used for production abc three phases PWM pulses. Control technique employed throughout this paper is shown below in Figure

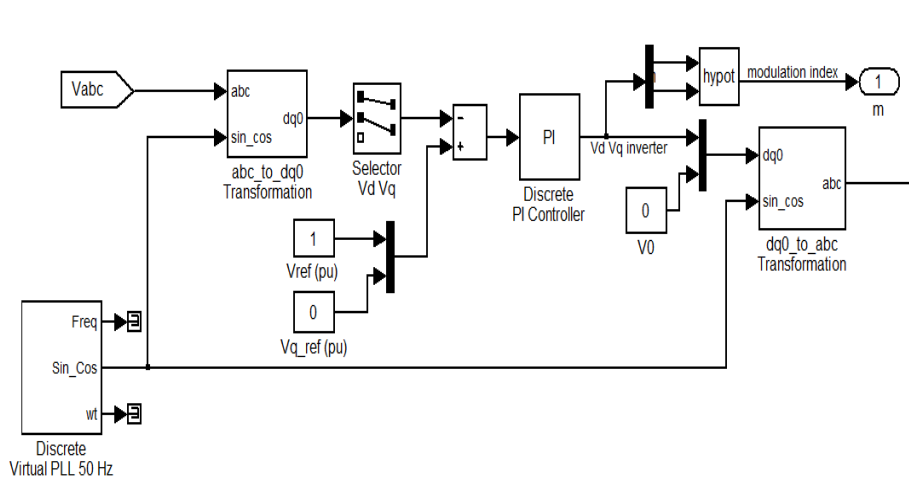

Figure 1 Schematic diagrams of control block.

A. Dynamic Voltage Restorer:

DVR is a recently proposed series connected solid state device that injects voltage into the system in order to regulate the load side voltage. It is normally installed in a distribution system between the supply and critical load feeder [6] as shown in Figure-2. Usually the connection is made via a transformer, but configurations with direct connection via power electronics also exist. The resulting voltage at the load bus bar equals to the sum of the grid voltage and the injected voltage from the DVR. The converter generates the reactive power needed while the active power is taken from the energy storage. The energy storage can be different depending on the needs of compensating. The DVR often has limitations on the depth and duration of the voltage dip that can compensate [8].

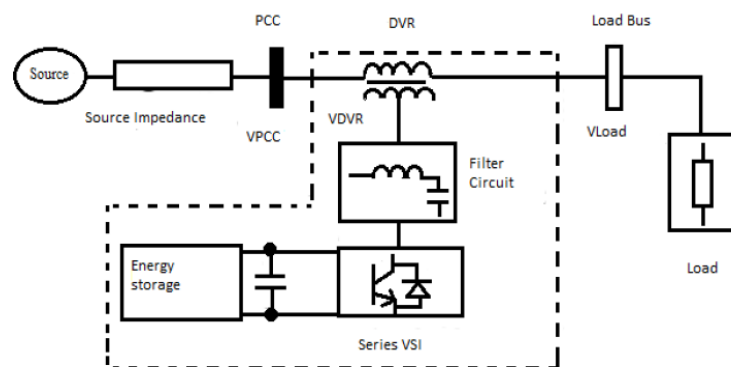

Figure 2 DVR series connected topology

The compensation for voltage sags using a DVR can be performed by injecting/absorbing reactive power or real power. When the injected voltage is in quadrature with the current at the fundamental frequency, compensation is achieved by injecting reactive power and the DVR itself is capable of generating the reactive power because DVR is self-supported with dc bus. But, DVR voltage can be kept in quadrature with the current only up to a certain value of voltage sag and beyond which the quadrature relationship cannot be maintained to correct the voltage sag i.e. if the injected voltage is in phase with the current, DVR injects real power and hence an energy storage device is required at the dc side of VSI. The control technique adopted should consider the limitations such as the voltage injection capability (inverter and transformer rating) and optimization of the size of energy storage [4].

B. Distribution Static Compensator:

A Distribution-STATCOM consists of a two-level VSI, a dc energy storage device, a coupling transformer connected in shunt to the distribution network through a coupling transformer as shown in Figure-3. The VSI converts the dc voltage across the storage device into a set of three-phase ac output voltages. These voltages are in phase and coupled with the ac system through the reactance of the coupling transformer. Suitable adjustment of the phase and magnitude of the DSTATCOM output voltages allows effective control of active and reactive power exchanges between the DSTATCOM and the ac system. Such configuration allows the device to absorb or generate controllable active and reactive power.

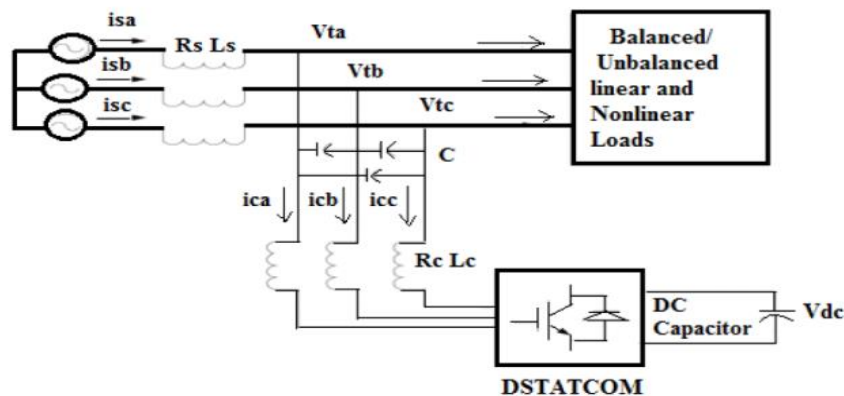

Fig-3: Schematic Diagram of DSTATCOM

IV. MATLAB MODELING AND SIMULATION

A. MATLAB Model of Uncompensated System:

A Distribution system is modeled and simulated using the MATLAB. The model is shown in Figure-4. The three-phase source of 220 KV is connected to step down transformer (220 kv/11kv) and secondary of transformer (11kv) is connected to pi section of length 21 km and a three phase load is also connected through a load bus.

A fault is applied at the distribution line and then analyzes system through scope showing voltage magnitude in per unit system.

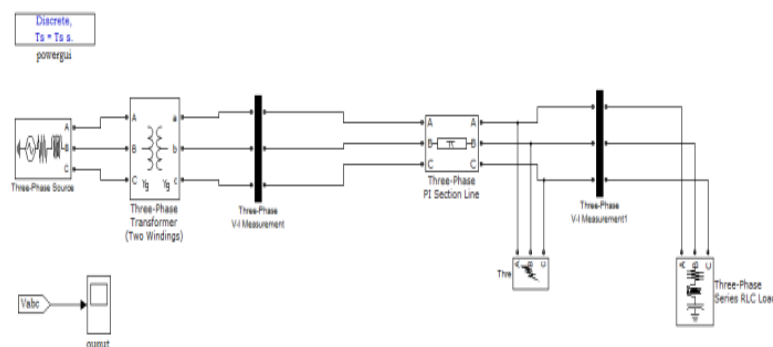

Figure 4 MATLAB model of DSTATCOM connected system

B. MATLAB Model of DVR:

The DVR is modeled and simulated using the MATLAB and its Simulink and Sim Power System toolboxes. The MATLAB model of the DVR connected system [4] is shown in Figure-5. DVR consists of a PWM inverter circuit and a DC Voltage source connected at the DC Link of VSI. The IGBT based PWM VSI is modeled using Universal Bridge Block from Power Electronics subset of Power System Block-set. The considered load is a lagging power factor load.

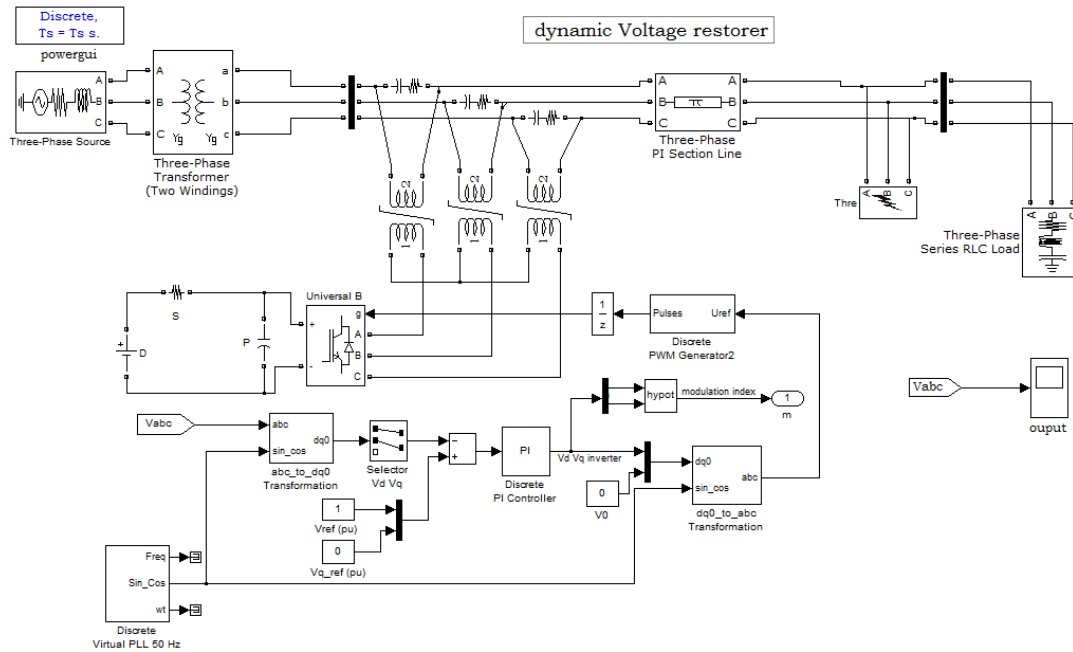

Figure 5 MATLAB model of DVR connected system

C. MATLAB Model of DSTATCOM:

A Distribution-STATCOM is used to regulate voltage on a 11-kV distribution network. A feeders (21 km) transmit power to loads connected at bus B2

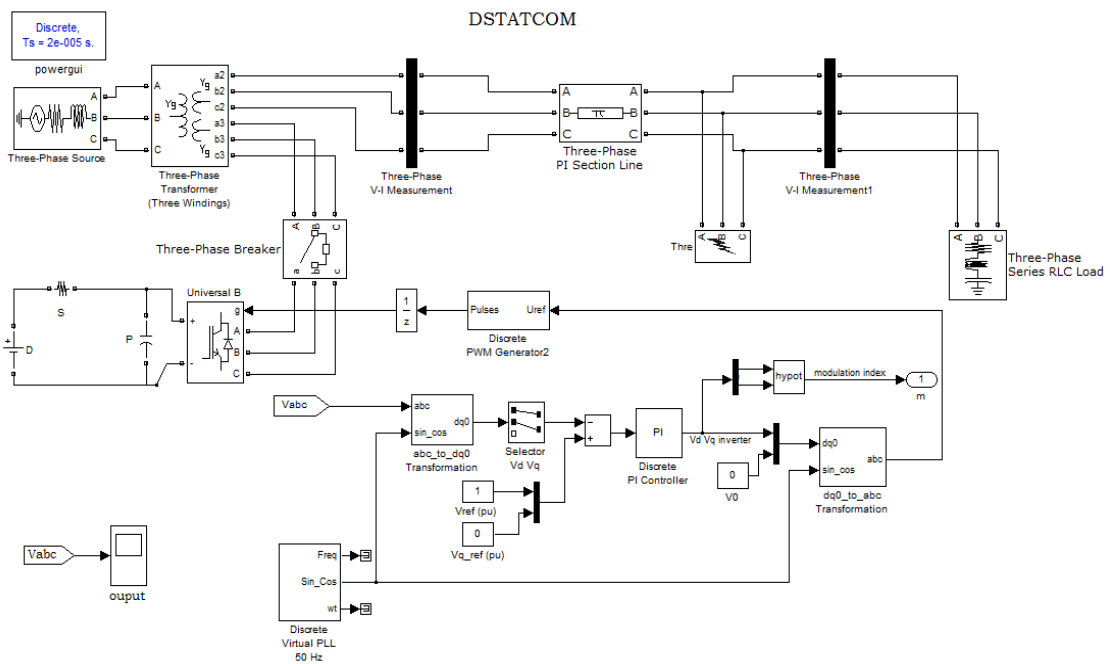

Figure 6 MATLAB model of DSTATCOM connected system

The D-STATCOM regulates bus B3 voltage by absorbing or generating reactive power. This reactive power transfer is done through the leakage reactance of the coupling transformer by generating a secondary voltage in phase with the primary voltage (network side). This voltage is provided by a voltage-sourced PWM inverter. When the secondary voltage is lower than the bus voltage, the D-STATCOM acts like an inductance absorbing reactive power. When the secondary voltage is higher than the bus voltage, the DSTATCOM acts like a capacitor generating reactive power.

V. RESULT AND DISCUSSION

A. Simulation Result of Uncompensated System during fault:

In simulation of uncompensated system when a three-phase short-circuit fault is applied at point A, during the period 200 ms. The voltage sag at the load point is almost 80% with respect to the reference voltage.

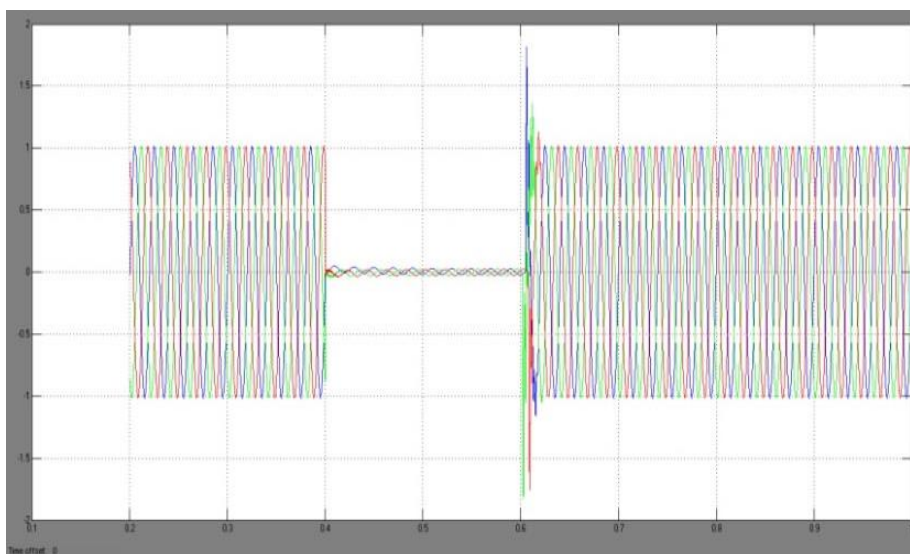

Fig.-7 Source Voltage waveform during Fault with Uncompensated system

B. Simulation Result of DVR during Fault:

Now simulate system with using DVR at point A where three-phase short-circuit fault has been applied. The voltage sag at the load point is now become almost 90% with respect to the reference voltage. Using the facilities available in MATLAB the DVR is simulated to be in operation only for the duration of the fault.

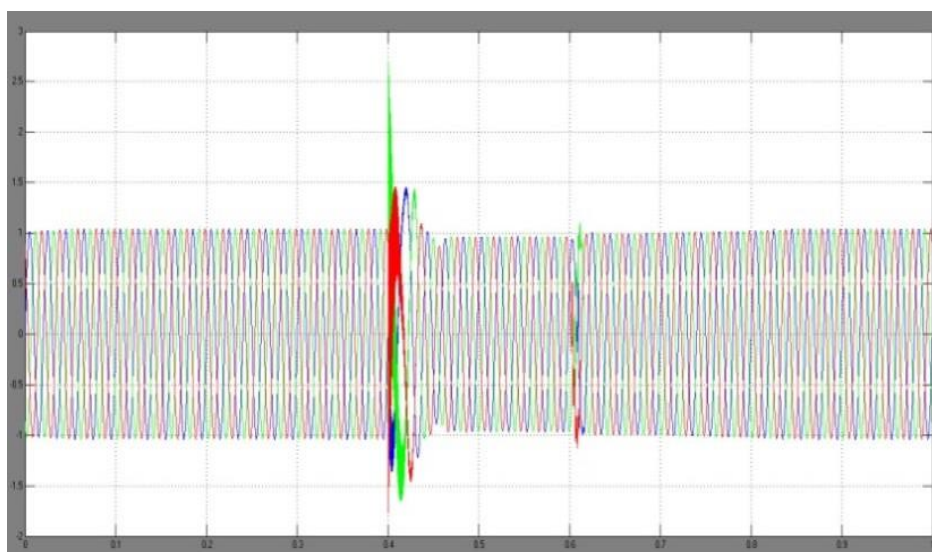

Fig.-8 Source Voltage waveform before Fault mitigation without DVR

C. Simulation Result of DSTATCOM during Fault:

Now simulate system with using DSTATCOM at point A where three-phase short-circuit fault has been applied. The voltage sag at the load point is now become almost 80% with respect to the reference voltage. Using the facilities available in MATLAB the DSTATCOM is simulated to be in operation only for the duration of the fault.

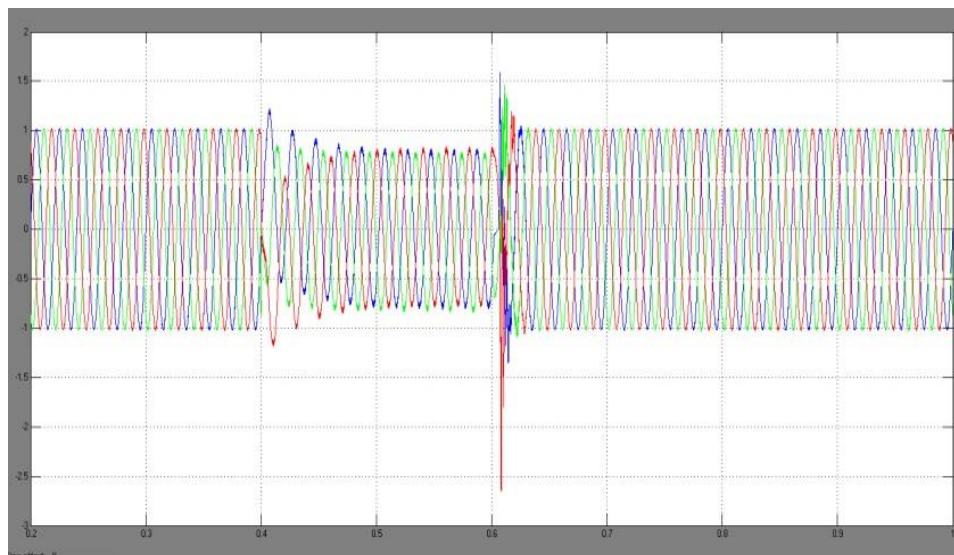

Figure 9 Source Voltage waveform before Fault mitigation without DSTATCOM

From the above result it is theoretically proved that DVR is more significant than DSTATCOM. The simulation graph helps us to make understand the comparison between them.

• Voltage Improvement

The load side voltage (in p.u.) during a fault condition of DVR and DSTATCOM are presented in this table. From this table we can see that DVR can deliver marginally greater voltage than DSTATCOM.

Table 1 Voltage Improvement

Voltage Magnitude(p.u.)	DSTATCOM	DVR
Before compensation	0.2 p.u.	0.2 p.u.
After compensation	0.8 p.u.	0.9 p.u.
improved voltage	0.6 p.u.	0.7 p.u.

• THD Analysis

Total harmonic distortion is an important criterion for power quality improvement. For the basis of presented harmonics in a power line THD is being calculated. This table created by the help of MATLAB FFT Analysis Result. During a fault condition THD of load side voltage presented in this table. From this presented table we can see that DVR is much better than DSTATCOM because the harmonics which is generated in the distribution line eliminated by the help of DVR system and the load voltage is approximately sinusoidal.

Table 2 THD Analysis

THD	DSTATCOM	DVR
Before Compensation	5.92	5.92
After Comensation	5.92	3.49

THD analysis of DSTATCOM

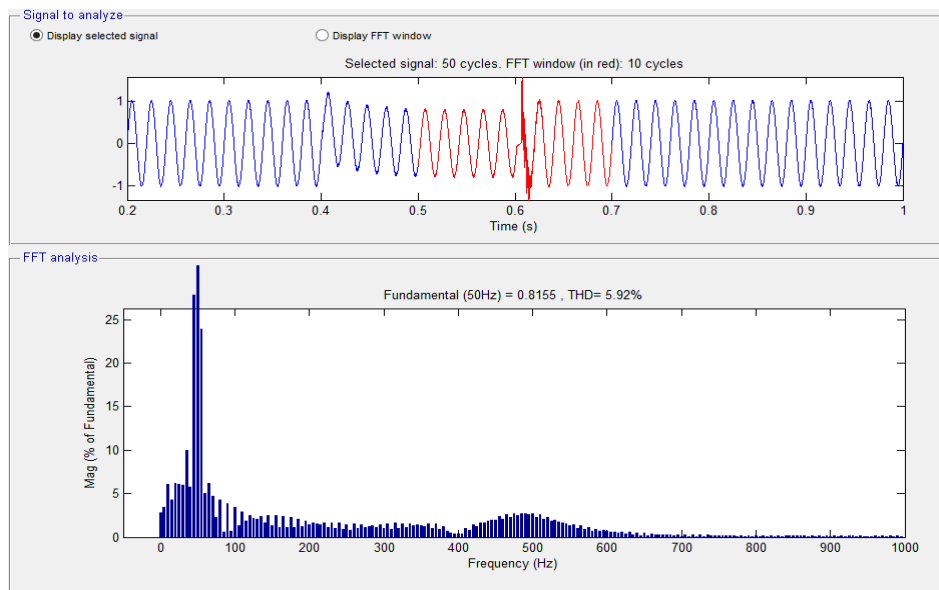

Figure 10 THD analysis of DSTATCOM

THD analysis of DVR

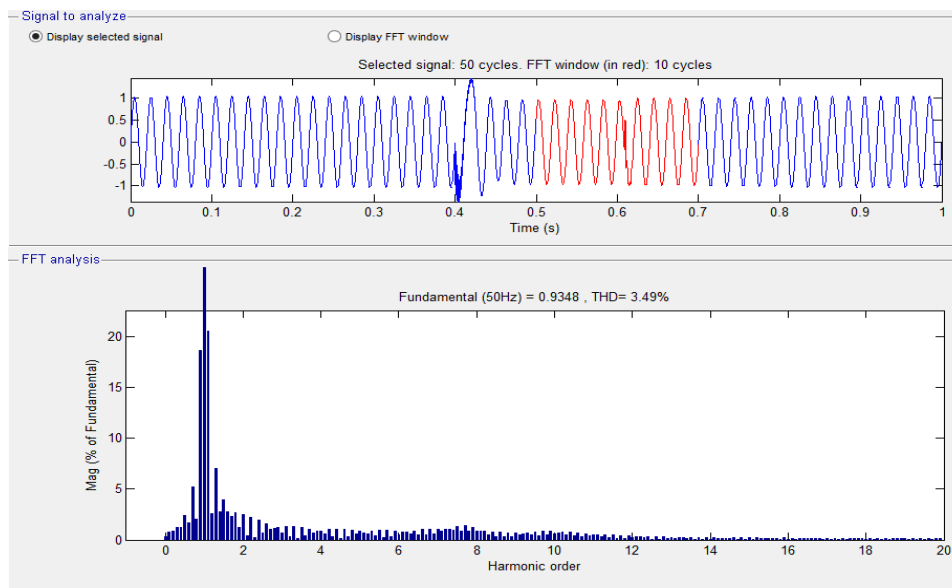

Figure 11 THD analysis of DVR

VI. CONCLUSION

This paper has presented the power quality problems such as voltage dips, swells and interruptions, and mitigation techniques of custom power electronic devices DVR, D-STATCOM. The design and applications of DVR and D-STATCOM for voltage sags, interruptions and swells, and comprehensive results are presented.

A new PWM-based control scheme has been implemented to control the electronic valves in the VSI used in the DSTATCOM and DVR. As opposed to fundamental frequency switching schemes already available in the MATLAB/SIMULINK, this PWM control scheme only requires voltage measurements. This characteristic makes it ideally suitable for low-voltage custom power applications. The simulations carried out showed that the DVR provides relatively better voltage regulation capabilities. It was also observed that the capacity for power compensation and voltage regulation of DSTATCOM depends on the rating of the dc storage device. The simulation results presented shows good accuracy with results.

REFERENCES

- [1] M. Bollen, "Understanding Power Quality Problems – Voltage Sags and Interruptions", IEEE Press Series on Power Engineering – John Wiley and Sons, Piscataway, USA (2000).
- [2] Math H.J. Bollen, Understanding power quality problems: voltage sags and interruptions, IEEE Press, New York, 2000
- [3] Performance of DVR under different voltage sag and swell conditions by T. Devaraju, V. C. Reddy and M. Vijaya Kumar VOL. 5, NO. 10, OCTOBER 2010 ISSN 1819-6608
- [4] Mitigation Of Voltage Sags/Swells Using Dynamic Voltage Restorer (DVR) Rosli Omarand and Nasrudin Abd Rahim VOL. 4, NO. 4, JUNE 2009 ISSN 1819-6608
- [5] Power Quality Enhancement Using Custom Power Devices by A. Ghosh and G. Ledwich. 2002. Kluwer Academic Publishers. ISBN 14020-7180-9
- [6] The Effect of DVR Location for Enhancing Voltage Sag by Rohanim Ibrahim, Ahmed M. A. Haidar, Zahim M., Herbert Iu
- [7] Control of Reduced Rating Dynamic Voltage Restorer with Battery Energy Storage System, by B. Sing, P. Joyprakash IEEE 2008,978-1-4244-1762-9/08
- [8] A novel Control Algorithm for Self Supported Dynamic voltage Restorer(DVR) by Himadri Ghosh, Pradip Kr. Saha and Goutam Kr. Panda IJSER,vol 3,ISSN 2229-5518
- [9] FACTS controllers in power transmission and distribution by K. R. Padiyar ISBN (13) : 978-81-224-2541-3
- [10] Modeling, Design and Analysis of Different Controllers for DSTATCOM by Bhim Singh, Senior Member, IEEE, Alka Adya, A.P.Mittal, Member, IEEE, 0-7803-9525-5/06
- [11] Distributed DSTATCOMs for Distribution Line Enhancement by Lasantha B. Perera, Gerard Ledwich and Arindam Ghosh